

IS : 2974 (Part I) - 1982

(Reaffirmed 1998)

Indian Standard

**CODE OF PRACTICE FOR
DESIGN AND CONSTRUCTION OF
MACHINE FOUNDATIONS**

**PART I FOUNDATION FOR RECIPROCATING
TYPE MACHINES**

(*Second Revision*)

Second Reprint MAY 1993

UDC 624.159.11 : 621.9-12

© *Copyright* 1982

**BUREAU OF INDIAN STANDARDS
MANAK BHAVAN, 9 BAHADUR SHAH ZAFAR MARG
NEW DELHI 110002**

Gr 6

December 1982

Indian Standard

CODE OF PRACTICE FOR
DESIGN AND CONSTRUCTION OF
MACHINE FOUNDATIONS

PART I FOUNDATION FOR RECIPROCATING
TYPE MACHINES

(*Second Revision*)

Foundation Engineering Sectional Committee, BDC 43

Chairman

PROF DINESH MOHAN

Representing

Central Building Research Institute (CSIR),
Roorkee

Members

DR R. K. BHANDARI

Central Building Research Institute (CSIR),
Roorkee

SHRI DEVENDRA SHARMA (*Alternate*)

CHIEF ENGINEER

Calcutta Port Trust, Calcutta

SHRI S. GUHA (*Alternate*)

SHRI M. G. DANDAVATE

The Concrete Association of India, Bombay

SHRI N. C. DUGGAL (*Alternate*)

SHRI A. G. DASTIDAR

In personal capacity (5 Hungerford Court, 121,
Hungerford Street, Calcutta)

SHRI V. C. DESHPANDE

The Pressure Piling Co (I) Pvt Ltd, Bombay

SHRI A. GOSAL

Stup Consultants Limited, Bombay

DIRECTOR (CSMRS)

Central Soil & Material Research Station,
New Delhi

DY DIRECTOR (CSMRS) (*Alternate*)

SHRI A. H. DIVANJI

Asia Foundations and Construction Pvt Ltd,
Bombay

SHRI A. N. JANGLE (*Alternate*)

SHRI R. K. DAS GUPTA

Simplex Concrete Piles (India) Private Limited,
Calcutta

SHRI H. GUHA BISWAS (*Alternate*)

DR JAGDISH NARAIN

Indian Geotechnical Society, New Delhi

PROF SWAMI SARAN (*Alternate*)

SHRI G. S. JAIN

G. S. Jain & Associates, Roorkee

SHRI ASHOK KUMAR JAIN (*Alternate*)

SHRI N. JAGANNATH

Steel Authority of India, Bokaro

SHRI A. K. MITRA (*Alternate*)

(*Continued on page 2*)

© Copyright 1982

BUREAU OF INDIAN STANDARDS

This publication is protected under the *Indian Copyright Act* (XIV of 1957) and reproduction in whole or in part by any means except with written permission of the publisher shall be deemed to be an infringement of copyright under the said Act.

IS : 2974 (Part I) - 1982

(Continued from page 1)

<i>Members</i>	<i>Representing</i>
JOINT DIRECTOR (DESIGNS) SHRI SUNIL BERY (<i>Alternate</i>)	National Buildings Organisation, New Delhi
JOINT DIRECTOR RESEARCH (GE)-I, RDSO	Ministry of Railways
JOINT DIRECTOR RESEARCH (B & S), RDSO (<i>Alternate</i>)	
DR R. K. KATTI	Indian Institute of Technology, Bombay
SHRI S. R. KULKARNI	M. N. Dastur & Co Pvt Ltd, Calcutta
SHRI S. ROY (<i>Alternate</i>)	
SHRI O. P. MALHOTRA	Public Works Department, Chandigarh Administration
SHRI A. P. MATHUR	Central Warehousing Corporation, New Delhi
SHRI V. B. MATHUR	Machenzies Limited, Bombay
SHRI T. K. D. MUNSI	Engineers India Limited, New Delhi
SHRI M. IYENGAR (<i>Alternate</i>)	
SHRI B. K. PANTHAKY	The Hindustan Construction Co Ltd, Bombay
SHRI V. M. MADGE (<i>Alternate</i>)	
SHRI M. R. PUNJA	Cemindia Co Ltd, Bombay
SHRI S. MUKHERJEE (<i>Alternate</i>)	
SHRI N. E. V. RAGHVAN	The Braithwaite Burn & Jessop Construction Company Limited, Calcutta
PROF GOPAL RANJAN	University of Roorkee, Roorkee
DR V. V. S. RAO	Nagadi Consultants Private Ltd, New Delhi
SHRI T. N. SUBBA RAO	Gammon India Limited, Bombay
SHRI S. A. REDDI (<i>Alternate</i>)	
SHRI ARJUN RIJHSINGHANI	Cement Corporation of India, New Delhi
SHRI O. S. SRIVASTAVA (<i>Alternate</i>)	
DR A. SARGUNAN	College of Engineering, Guindy
SHRI S. BOMMINATHAN (<i>Alternate</i>)	
SHRI K. R. SAXENA	Engineering Research Laboratories, Government of Andhra Pradesh, Hyderabad
BRIG OMBIR SINGH	Engineer-in-Chief's Branch, Army Headquarters, New Delhi
LT-COL K. P. ANAND (<i>Alternate</i>)	
SHRI N. SIVAGURU	Ministry of Shipping and Transport, New Delhi
SHRI K. P. SARKAR (<i>Alternate</i>)	
SUPERINTENDING ENGINEER (DESIGNS)	Central Public Works Department, New Delhi
EXECUTIVE ENGINEER (DESIGNS) V (<i>Alternate</i>)	
SHRI M. D. TAMBEKAR	Bombay Port Trust, Bombay
DR A. VARADARAJAN	Indian Institute of Technology, New Delhi
DR R. KANIRAJ (<i>Alternate</i>)	
SHRI G. RAMAN, Director (Civ Engg)	Director General ISI (<i>Ex-officio Member</i>)

Secretary

SHRI K. M. MATHUR
Deputy Director (Civ Engg) ISI,

(Continued on page 22)

Indian Standard

CODE OF PRACTICE FOR DESIGN AND CONSTRUCTION OF MACHINE FOUNDATIONS

PART I FOUNDATION FOR RECIPROCATING TYPE MACHINES

(Second Revision)

0. F O R E W O R D

0.1 This Indian Standard (Part I) (Second Revision) was adopted by the Indian Standards Institution on 26 July 1982, after the draft finalized by the Foundation Engineering Sectional Committee had been approved by the Civil Engineering Division Council.

0.2 Installation of heavy machinery has assumed increased importance in the wake of the vast programme of industrial development in the country. Foundations for these machines have to be specially designed taking into consideration the impact and vibration characteristics of the load and the properties of soil under dynamic conditions. While many of the special features relating to the design and construction of such machines foundations will have to be as advised by the manufacturers of these machines, still a large part of the details will have to be according to certain general principles of design covering machine foundations. This standard is intended to lay down these general principles. This part, which is the first of a series of standards relating to machine foundations, deals with machines of the reciprocating type for which rigid-block type foundations are generally used. This standard was first published in 1964 and revised in 1969. In this revision, the principal modifications made are in respect to providing additional information of pile foundation, grouting and inclusion of guidelines for installation of anti-vibration mountings and testing and measurement of vibration.

0.3 For the purpose of deciding whether a particular requirement of this standard is complied with, the final value, observed or calculated, expressing the result of a test or analysis, shall be rounded off in accordance with IS : 2-1960*. The number of significant places retained in the rounded off value should be the same as that of the specified value in this standard.

*Rules for rounding off numerical values (revised).

1. SCOPE

1.1 This standard covers the design and construction of foundations for machines of the reciprocating type which normally generate steady state vibration and is of a size for which a rigid block type foundation is normally used.

2. TERMINOLOGY

2.0 For the purpose of this standard, the definitions of the following term shall apply (see Fig. 1).

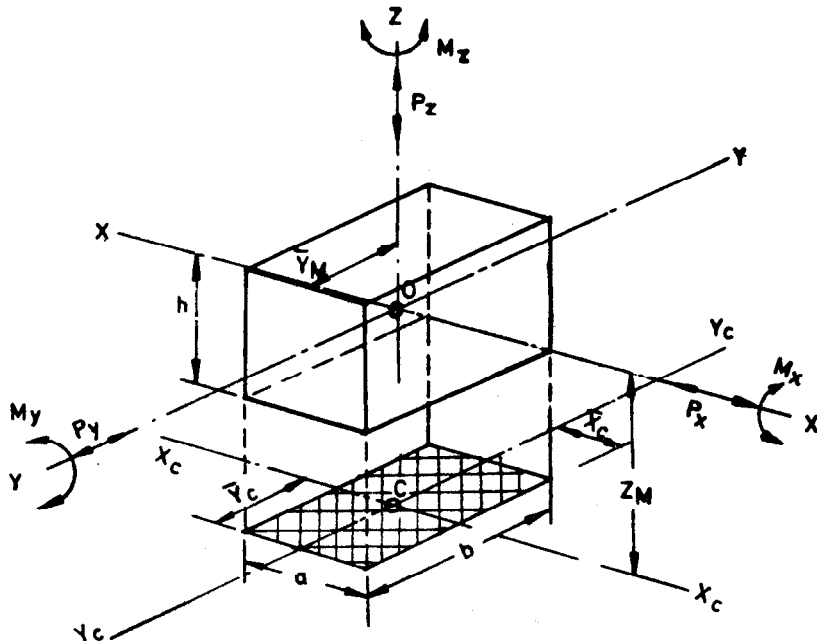

Lateral	P_x	
Longitudinal	P_y	
Vertical	P_z	$O =$ Combined Centroid of Foundation and Machinery System
Pitching	M_x	
Rocking	M_y	$C =$ Centroid of Bearing Surface
Yawing	M_z	

FIG. 1 AXES AND CO-ORDINATES

2.1 Supporting Ground — That part of the ground carrying load arising from the machine and foundation.

2.2 Foundation — The part of the structure in direct contact with, and transmitting loads to the supporting ground.

2.3 Forces and Couples

2.3.1 External Forces — The unbalanced part of the periodic inertia forces caused by the acceleration and deceleration of reciprocating parts. The primary inertia force has one complete cycle and the secondary inertia force two cycles per revolution of the crank shaft.

2.3.2 Vertical Force — An unbalanced force at machine operation frequency or twice the operation frequency, or both, acting in the directions of axis Z .

2.3.3 Horizontal Force — An unbalanced force at machine operation frequency or twice machine operation frequency, or both acting in the directions of axis X .

2.3.4 External Couple — A moment which occurs when one inertia force is balanced by another but in a separate line of action. For foundation design it is usually necessary to consider only the primary and secondary vertical and horizontal couples.

2.3.5 Vertical Couple — An unbalanced couple at machine operation frequency or twice the machine operation frequency, or both acting in the planes of axes YZ .

2.3.6 Horizontal Couple — An unbalanced couple at machine operation frequency or twice the machine operation frequency, or both, acting in the planes of axes XY .

2.4 Torque

2.4.1 Harmonic Torque Reaction — Turning moment in plane of axes XZ , the frequencies of which depend on number of cylinders and configuration of the machine.

2.5 Periodic Motion — The motion which repeats itself in all its particulars at regular intervals of time is called the periodic motion.

2.5.1 Aperiodic Motion — The motion which does not repeat itself at regular intervals of time is called aperiodic motion.

2.6 Damping — Damping is associated with energy dissipation and is the internal resistance offered by a foundation system to the vibration of machine. It is termed viscous damping when the force of damping is directly proportional to the instantaneous velocity of the oscillating system.

2.6.1 Damping Constant (C) — Constant of proportionality relating force of damping with instantaneous velocity of motion.

2.6.2 Critical Damping (C_c) — The magnitude of damping at which the motion of the system changes from periodic to aperiodic.

where $C_c = 2\sqrt{mk}$ for single degree of freedom system

2.6.3 Damping Factor — The ratio of the damping constant (C) to the critical damping (C_c) of the system.

2.7 Amplitude of Motion — The distance that a body moves from its position of rest when subjected to vibration.

2.8 Frequency — The number of times a periodic motion repeats itself expressed in revolutions or cycles per minute (f).

2.8.1 Operation Frequency — The rotating speed of the main drive in cycles per second or the frequency of the periodic force acting on the system.

NOTE — System means the machine, the foundation block and soil.

2.8.2 Angular Frequency (ω) — The frequency expressed in radians per second.

2.8.3 Natural Frequency (f_n) — The frequency of free vibration of a body.

2.8.4 Disturbing Frequency — The frequency of a periodic force.

2.8.5 Limiting Frequencies — If a system possesses ' n ' degrees of freedom having ' n ' natural frequencies $f_1, f_2, f_3, f_4, \dots \dots \dots f_n$, the minimum and maximum of such frequencies, f_{min} and f_{max} are known as limiting frequencies of the system.

2.8.6 Frequency Ratio (f/f_n) — The ratio of the operating frequency to the natural frequency.

2.9 Degrees of Freedom of a System — The degree of freedom of a system is defined as the number of coordinates required to describe the displaced position of the system (see Fig. 2).

2.10 Resonance — When the frequency of the forced vibration (operating frequency of the machine) equals the natural frequency of the foundation soil system the condition of resonance is reached.

2.11 Mass Moments of Inertia — The resistance of a mass to rotation and equal to its mass times the radius of gyration squared.

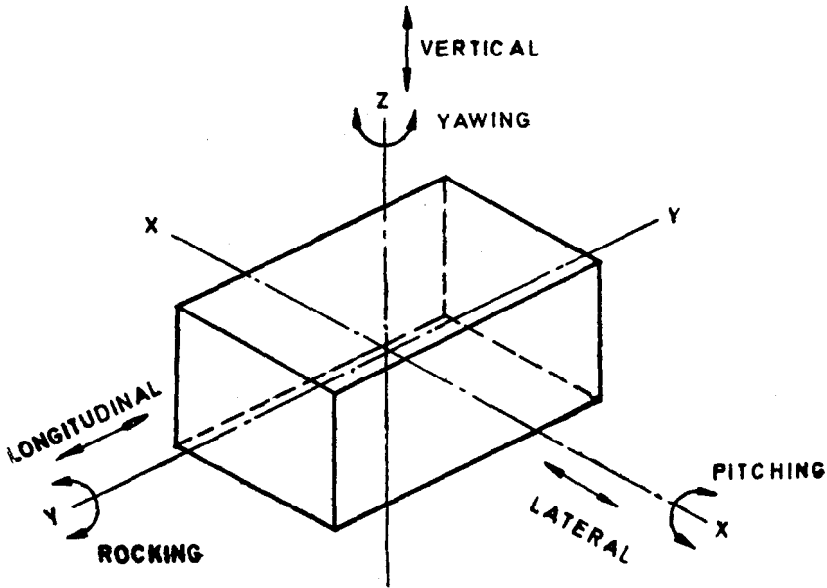

Lateral	P_x	Pitching	M_{xx}
Longitudinal	P_y	Rocking	M_{yy}
Vertical	P_z	Yawing	M_{zz}

The axis YY is parallel to the crank shaft.

FIG. 2 SYSTEM OF AXES AND THE SIX DEGREES OF FREEDOM

2.12 Mass-Spring System

2.12.1 Single Mass Spring System — A rigid body supported by a number of springs, such a system has six natural frequencies, three of them being translational or three cartesian, co-ordinate axes and the other three being rotational on three planes in a cartesian co-ordinate system.

2.12.2 Multiple Mass-Spring System — A number of rigid bodies connected by a series of relatively flexible springs. The natural frequencies depend on the number of degrees of freedom being defined as the number of co-ordinates required to identify a point on the rigid body.

2.13 Fatigue Factor or Fatigue Coefficient — The factor of safety utilized to obtain equivalent static force for a dynamic force so as to take care of reduction in the strength of the concrete and steel due to repeated loading. The factor should be assumed as 3 unless otherwise specified.

3. NOTATIONS

3.1 The notations given in Appendix A shall apply.

4. NECESSARY DATA

4.1 Data to be Provided by Machine Manufacturer — The manufacturer should provide information as outlined in 4.1.1 to 4.1.3.

4.1.1 *General*

- a) Description of driving and driven machinery,
- b) Operating speed or speed ranges,
- c) Number and arrangement of cylinders,
- d) Distance between axis of main shaft of the machine and the top face of foundation,
- e) Maximum rated output,
- f) Gear box ratio where applicable, and
- g) Maximum operating temperature in the bases of the machine.

4.1.2 *For Static Design*

4.1.2.1 A detailed loading diagram comprising plan, elevation and section showing details of communication and point of all loads on foundation.

4.1.2.2 A detailed drawing showing the position and size of mounting feet and details of holding down bolts.

4.1.3 *For Dynamic Design*

4.1.3.1 Details of out of balance forces and couples shall be given, together with associated frequencies for all possible modes of vibration for driving and driven machinery. These include the following:

- a) External forces,
- b) External primary couples,
- c) External secondary couples, and
- d) Harmonic torques.

4.1.3.2 Mass moments of inertia of driving and driven machine about three principal axes shall be indicated.

4.1.3.3 Additional information relating to specific machines, as given below, shall be provided where necessary:

- a) Loads due to dynamic short circuit conditions, and
- b) Loads due to an abnormal sudden stoppage.

4.1.3.4 Where it is found necessary to use anti-vibration mountings, the type and positions be indicated.

4.2 Data on Ground and Site Conditions — The following soil data shall be known:

- a) Soil profile and soil characteristics up to a depth at least three times the expected mean plan dimension of the foundation which can be taken as the square root of the expected area, or hard strata.
- b) Soil investigation to the extent necessary in accordance with IS : 1892-1979* and for the determination of dynamic properties of soil in accordance with IS : 5240-1977†.
- c) The relative position of the water table below ground at different times of the year.

5. DESIGN CRITERIA

5.1 General

5.1.1 The foundation structure of machine shall be isolated at all levels from the main building and from other foundations as far as possible.

5.1.2 Overhanging cantilevers where unavoidable shall be designed to ensure rigidity against vibration.

5.1.3 All machine foundations shall satisfy two fundamental criteria; that resonance does not occur between the frequencies of the pulsating loads and natural frequency of foundation/soil system and also the amplitude of vibration does not exceed safe limits. Design criteria based on frequency and amplitude limits can be classed as follows:

- a) Limits set by the possibility of damage or uneconomic wear to machinery or associated equipment or both,
- b) Limits set by the possibility of damage to building structures,
- c) Limits of structural borne vibrations to ensure confort of person, and
- d) Limits set by possibility of disturbance of ground resulting in unacceptable settlement of foundation.

*Code of practice for subsurface investigation for foundations (*first revision*).

†Method of test for determination of dynamic properties of soil (*first revision*).

5.2 Frequency Ratio — Wherever possible the natural frequency of the foundation soil-system shall be higher than the highest disturbing frequency and the frequency ratios shall not be normally less than 0.4. Where this is not possible, the natural frequency of the foundation-soil system shall be kept lower than the lowest disturbing frequency. The frequency ratios in such cases shall not be lower than 1.50. While the above criteria shall be applied to all possible modes of vibration, it may be permitted to operate machines closer to the resonance in certain modes of vibration provided the resulting amplitudes do not exceed the permissible limit.

NOTE — Even though machine may be balanced, minor disturbing forces can occur due to manufacturing tolerances and other causes, for sensitive installations, the frequencies arising from these may have to be considered.

5.3 Permissible Amplitudes

5.3.1 Limitations of Vibration Amplitude to Avoid Damage to Machinery — This shall be specified by the manufacturer and shall in no cases be exceeded. Where no specific limit has been stated by the manufacturer, it may be taken that foundation satisfying the following amplitude criteria shall provide a satisfactory base for machinery.

5.3.2 Limitations of Vibration Amplitude to Avoid Damage to Machinery — The damage in neighbouring buildings due to resonance will be negligible if the amplitude vibration of the foundation is less than 200 microns at frequencies below 20 Hz, where the disturbing frequency exceed 20 Hz, a lower amplitude may be necessary for certain installations, when a value corresponding to the frequency may be read off line ADD' of Fig. 3.

5.3.3 Limitation of Vibration Amplitude to Avoid Discomfort of Persons — For low speed machines, it is unlikely that foundations which satisfy 5.3.2 will produce vibrations of sufficient amplitude to be disturbing to persons. In special cases where there are particular reasons to avoid discomfort to personnel, a low permissible amplitude corresponding to operating frequency of machine can be read off from Fig. 3.

5.3.4 Limitations of Amplitude to Avoid Settlement — For most soil types, foundations for low speed machines designed to limiting amplitude of 200 microns will not suffer undue settlement due to dynamic loads. In case of some soils like loose sands and silts in conjunction with high water table, there is a possibility of significant settlement to occur. In all such cases, it shall be preferable to consolidate the soil underneath the foundation.

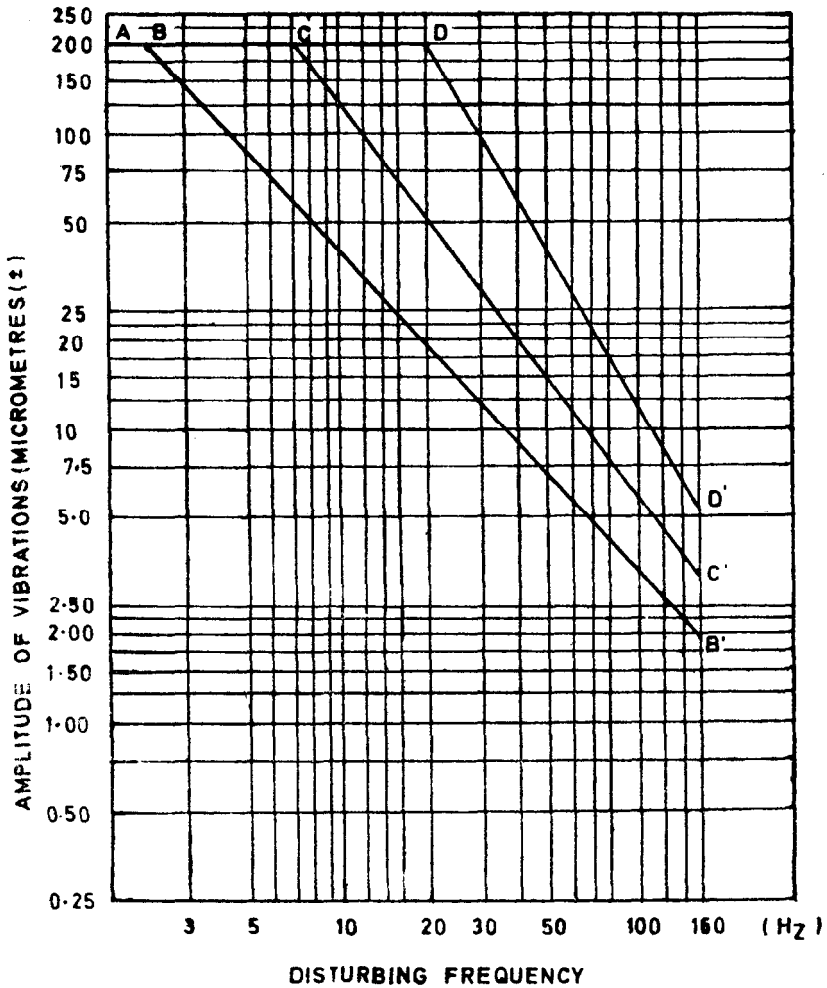

Line ADD' Limit to Avoid Damage to Buildings

Line ACC' Limit to Avoid Serious Discomfort to Persons

Line ABB' Limit to Ensure Reasonable Comfort to Persons

NOTE — These Limits do not include any factor of safety.

FIG. 3 AMPLITUDE LIMITS OF FOUNDATION BLOCK

5.4 Concrete Foundation Design

5.4.1 General Conditions — Normally concrete block foundations are designed for reciprocating machines. Both the foundations and machines are usually taken as a single body resting on an elastic bedding. (Sub-soil or resilient mounting). The foundation is subject to oscillations at determinable frequencies in six degrees of freedom (Fig. 2).

Pile foundations may be used in cases where the soil conditions are unsuitable to support block foundation or when natural frequency of the block foundations needs to be raised in cases where it is impossible to alter dimensions or when amplitudes or settlement or both need to be reduced.

Cellular foundations may be used in special cases where it is necessary to maintain the rigidity of a block foundation but with mass saving of concrete. Wherever possible provision shall be made in cellular foundations to add mass by filling the voids to adjust the natural frequency of foundation block provided this does not result in additional settlement.

5.4.2 Dimensions of Concrete Foundation Blocks — For initial dimensioning of the concrete foundation blocks, the following empirical rules may be allowed.

5.4.2.1 Mass of the foundation shall be greater than that of the machine.

5.4.2.2 The eccentricity of foundation system along axis XX/YY shall not exceed 5 percent of the length of the corresponding side of the contact area. In addition, centre of gravity of machine and foundation shall be if possible below the top of foundation block.

5.4.2.3 To ensure reasonable stability in the case of vertical machines, the total width of the foundation (measured to right angles to shaft) shall be at least equal to the distance from the centre of the shaft to the bottom of the foundation. In case of horizontal machines, where cylinders are arranged laterally the width shall be greater.

5.4.2.4 The proportion of foundation block shall be such to ensure stability.

5.4.3 Final Design of Foundation Blocks — The final dimensions of a concrete foundation shall be derived from vibration calculations and shall consider:

- a) The dimensions of foundations by empirical rules,
- b) The bearing pressure due to dead and imposed load,
- c) The natural frequencies of the system for six modes of vibrations,

- d) The relationship between the exciting frequency and natural frequency of the foundation-soil system,
- e) Calculated amplitudes in the various modes of vibration, and
- f) Influence of water table specially when at a high level.

Appendix B gives the design procedure for an un-damped system. However, damping can also be considered in certain cases.

5.4.3.1 Full value of permissible stresses for steel and concrete as specified in IS : 456-1978* shall be allowed if dynamic loads are considered in detailed design by applying suitable dynamic and fatigue factors.

5.4.3.2 The following dynamic elastic modulus of concrete may be used in design:

<i>Grades of Concrete</i>	<i>Dynamic Elastic Modulus</i>
	kgf/cm ²
M 15	250 000
M 20	300 000
M 25	340 000
M 30	370 000

5.4.3.3 The soil stress below the foundations shall not exceed 80 percent of the allowable stress under static loading determined in accordance with IS : 6403-1981†. When seismic forces are considered allowable stress in the soil shall be increased as specified in IS : 1893-1975‡.

5.4.4 Supporting foundation blocks on end-bearing or friction piles shall be considered in cases where there is need to make a significant change in frequency in one or more modes of vibration or dead loads.

Pile caps where used as a foundation block shall be of such a size as to meet all design criteria, and be not less than 60 cm thick.

5.4.4.1 Requirement of piled foundations — The most usual reasons for adoption of piled foundation are as follows:

- a) When pressure on the soil under the block exceeds the permissible bearing pressure;

*Code of practice for plain and reinforced concrete (*third revision*).

†Code of practice for determination of bearing capacity of shallow foundations (*first revision*).

‡Criteria for earthquake resistant design of structures (*third revision*).

- b) When a foundation is found to be subject to resonance, or when an increase in the mass of the block is either unduly wasteful in material or ineffective due to the danger of resonance in other modes;
- c) When a block foundation is low tuned by one mode and high tuned by other and desirable or specified frequency ratios cannot be maintained simultaneously;
- d) When the amplitudes of movement of a block foundation are in excess of their permissible values;
- e) Piled foundation shall be used when a raft foundation is liable to suffer a differential settlement exceeding the permissible limit; and
- f) Piles may be used to minimize the effect of ground borne vibration on surrounding foundations and equipment.

5.4.4.2 Evaluation of pile soil stiffness — Pile soil stiffness factors both in vertical and horizontal (see IS : 9716-1981*) modes of vibration shall preferably be determined by conducting *in situ* test on piles. In cases, where it becomes difficult to conduct this test, the values can be taken from some standard publications. The centre of gravity of the system, that is, foundation and machine shall be located within 5 percent of the length of foundation to concerned axis with respect to the centre of gravity of the pile group.

5.4.4.3 Design considerations

- a) Pile-soil stiffness factors both in vertical and horizontal modes of vibration shall be determined by conducting *in situ* dynamic tests on piles. For preliminary design however the computational method of estimation of pile-soil stiffness can be adopted.
- b) Usually *in situ* dynamic tests are conducted on single pile with free head condition. In actual practice the pile shall be used in a group with pile heads largely restrained by the pile cap. Allowance shall be made for these factors in evaluation of pile-soil stiffness to be adopted for design. Failure to take account of these factors will lead to error in estimating stiffness of the system.
- c) After evaluating the pile-soil stiffness, the design shall be carried out in the same way as for the block foundation resting directly on soil.

*Guidelines for lateral dynamic load test on piles.

5.4.5 Minimum Reinforcement in Block Foundations

5.4.5.1 Minimum reinforcement in the concrete block shall be not less than 25 kg/m^3 . For machines requiring special design considerations of foundations, like machines pumping explosive gases the reinforcement shall be not less than 40 kg/m^3 .

5.4.5.2 The minimum reinforcement in the block shall usually consist of 12 mm bars spaced at 200/250 mm centre to centre extending both vertically and horizontally near all the faces of the foundation block.

5.4.5.3 The following points shall be considered while arranging the reinforcements:

- a) The ends of mild steel (if used) shall always be hooked irrespective of whether they are designed for tension or compression,
- b) Reinforcement shall be used at all faces,
- c) If the height of foundation block exceeds one metre, shrinkage reinforcement shall be placed at suitable spacing in all three directions, and
- d) Reinforcement shall be provided around all pits and openings and shall be equivalent to 0.50 to 0.75 percent of the cross-sectional area of the opening.

5.4.6 Anti-Vibration Mountings

5.4.6.1 Where it is found to be impracticable to design a foundation consisting of a simple concrete block resting on the natural soils to give satisfactory dynamic characteristics, it may be possible to reduce the transmitted vibrations to acceptable levels by means of anti-vibration mounting.

5.4.6.2 Depending upon the nature of the machinery and the installation, the anti-vibration mounting may be used:

- a) Between machinery and foundation, and
- b) Between a foundation block and a supporting system.

6. CONSTRUCTION

6.1 Concrete — Concrete strength shall be specified on the basis of 28-day cube strength. The concrete grade shall be at least M-15 (according to IS : 456-1978*).

*Code of practice for plain and reinforced concrete (*third revision*).

6.2 Continuity of Work — Foundation block shall preferably be cast in single continuous operation. In case of very thick blocks (exceeding about 5 m) if needed, construction joints can be provided. In such a event construction joint shall be suitably designed by the design engineer and shown in working drawing. In the event of an unforeseen interruption in concrete, the resulting unavoidable joint shall be considered as a construction joint and treated in the same way as construction joints.

6.3 Cement Grout

6.3.1 Cement grout used for fitting or embedding shall consist of one part of Portland cement and two parts of clean sharp sand mixed to a moist consistency sufficient to facilitate the grout being fully worked under all seatings. Quick setting cement shall not be used.

6.3.2 Additives may be employed to give non-shrink properties to cement grout. In this case the ratio of cement and sand may be varied according to the instruction of manufacturer.

6.3.3 Cement grout shall be placed within a period commensurate with cement type but not later than one hour from the time of mixing.

6.4 Grouting

6.4.1 All metallic and concrete surfaces shall be thoroughly cleaned and washed to clean all dirt, oil, grease, loose particles and cement laitance. The concrete surfaces shall be roughened and saturated with clean water and kept wet for at least 24 hours and all surplus water removed and surfaces cleaned, oil free with compressed air if required before commencement of grouting.

6.4.2 Provision shall be made if required to avoid trapping air. Air relief holes shall be provided, if necessary.

6.4.3 Forms shall be high enough to provide a head of the grout on all sides which shall be about 150 mm high on side from which cement grout is to be poured. Forms shall be placed with sufficient clearance to the edges of the bases to enable the grout to be properly worked into position.

6.4.4 Forms shall be strong and secure and well covered to prevent leakage. The cement grout shall be poured from one side to avoid forming air pockets and be carried out continuously without interruption so that filling is continuous and dense.

6.4.5 On completion of the curing of the grout underfill the machine shall be finally checked to ensure that its alignment is acceptable.

6.4.6 Exposed surfaces of grout and concrete shall be prepared and given two coats of an oil and alkali resistant coating.

7. TESTING AND MEASUREMENT OF VIBRATION

7.1 General — Testing of a foundation block prior to the initial running of the machinery may, where warranted be carried out to determine the natural frequencies in various modes of vibration and the amplitudes due to dynamic forces likely to occur either during normal running or during emergency or adverse running conditions of the machine. The observation can also be made during the operation of machines.

7.2 Excitation — In case where blocks are to be tested prior to the running of machines, foundation blocks may be excited either by an electromagnetic or hydraulic vibrator. The block shall be excited in same modes of vibration as is expected from the operating machinery. The amplitudes of motion which can be induced with a scale down disturbing force may be significantly smaller than those expected in the operation of machine. Allowance may have to be made for the non-linearity of soil response.

7.3 Measurements

7.3.1 The vibrations shall be measured by transducers having a linear response over the range 2 to 200 Hz. The accuracy of transducers shall be better than 10 percent and they shall respond to a uniaxial motion with more than 10 percent cross sensitivity.

7.3.2 The transducers shall be preferably piezo electric type or geophones meeting the requirements as in **7.3.1**.

7.3.3 The transducers shall be mounted firmly to the foundation. The transducers shall not be merely rested on the foundation or held with hand.

7.3.4 Transducers shall preferably be placed on extremities of the upper-most surface of the block and as near as possible to the axis of X and Y (see Fig. 1).

7.3.5 In order to gain full picture of the behaviour of a block, it shall be desirable to use a multiple channel recorder with 'filter', single channel recorder can also be used in small installations.

7.3.6 It shall be preferable to use Vibration Analyser which can measure frequency and amplitude of vibration simultaneously.

APPENDIX A

(Clause 3.1)

NOTATIONS

SYMBOL	DESCRIPTION	UNIT
A	Area of foundation in contact with soil	cm^2
A_h	Horizontal amplitude of foundation subjected to horizontal force P_x and moment M_t	cm
A_z	Vertical amplitude of foundation subjected to vertical force P_z	cm
$A\phi$	Rotational amplitude of foundation subjected to horizontal force P_x and moment M_t	radian
C	Damping constant	dimensionless
C_c	Critical damping	kg-s/cm
C_u	Coefficient of elastic uniform compression of soil	kg/cm^3
C_τ	Coefficient of elastic uniform shear of soil	kg/cm^3
$C\phi$	Coefficient of elastic non-uniform compression of soil	kg/cm^3
e	Eccentricity of eccentric weight of rotating parts	cm
f	Frequency	c/s
f_n	Natural frequency	c/s
f_{n1}, f_{n2}	First and second natural frequencies of foundation subjected to horizontal vibration	c/s
f_{n1}, f_{n2}, f_{n3}	First, second and third natural frequencies of foundation when centre of gravity of mass of machine and foundation and the centroid of the foundation contact area with soil lies on vertical plane but not on the same vertical line	c/s
f_{nx}	Horizontal resonance frequency of foundation and soil system	c/s
f_{nz}	Vertical resonance frequency of foundation and soil system	c/s

SYMBOL	DESCRIPTION	UNIT
$f_n\phi$	Rotational resonance frequency of foundation and soil system	c/s
h	Height of the top surface of the foundation above the centre of gravity of the foundation and machine	cm
I	Moment of inertia of contact area with respect to the axis of rotation passing through the centroid of the area	cm ⁴
k	Stiffness of spring	kg/cm
L	Distance from mass centre of gravity of the vibrating system with respect to the axis of rotation	cm
M_i	Dynamic moment	kg/cm
M_m	Mass moment of inertia of the vibrating system with respect to the axis of rotation passing through C G of the system	kg-cm-s ²
M_{m_0}	Mass moment of inertia of the vibrating system with respect to the axis of rotation passing through centroid of contact area of foundation with soil	kg-cm-s ²
m	Mass of vibrating system	kg-s ² /cm
m_0	Mass of eccentric weight of rotating parts	kg-s ² /cm
P_a	Oscillating force applied at the centre of gravity of vibrating mass	kg
W	Weight of foundation and machine	kg
ε	Eccentric distance from centroid of contact area of foundation with soil to the C G of mass of machine and foundation	cm
w	Circular frequency	radian/s
ω_n	Circular natural frequency	radian/s

APPENDIX B

(Clause 5.4.3)

ANALYSIS FOR THE DETERMINATION OF NATURAL FREQUENCIES AND AMPLITUDES OF FOUNDATIONS ACCOMPANIED BY SIMULTANEOUS ROTATION, SLIDING AND VERTICAL DISPLACEMENT (MASS SPRING ANOLOGY)

B-1. Limiting Natural Frequencies — The limiting natural frequencies shall be calculated as follows:

$$f_{n\phi}^2 = \frac{C_\phi I - WL}{4\pi^2 M_{m0}}$$

$$f_{nz}^2 = \frac{C_u A}{4\pi^2 m}$$

$$\text{and } f_{nx}^2 = \frac{C_T A}{4\pi^2 m}$$

B-2. Check on Design

B-2.1 When the centre of gravity of mass of machine and foundation and centroid of contact area of foundation lie on the same vertical line, the vertical vibration of foundation is independent of vibrations in horizontal direction and rotation about the horizontal axis. The natural frequencies should be calculated as follows:

$$f_{nz} = \frac{1}{2\pi} \sqrt{\frac{C_u A}{m}}$$

$$f_{n1}^2 = \frac{1}{2\gamma} \left[f_{n\phi}^2 + f_{nz}^2 - \sqrt{(f_{n\phi}^2 + f_{nz}^2)^2 - 4\gamma f_{n\phi}^2 f_{nz}^2} \right]$$

$$f_{n2}^2 = \frac{1}{2\gamma} \left[f_{n\phi}^2 + f_{nz}^2 + \sqrt{(f_{n\phi}^2 + f_{nz}^2)^2 - 4\gamma f_{n\phi}^2 f_{nz}^2} \right]$$

where $\gamma = M_m/M_{m0}$.

Amplitudes are calculated as follows:

$$A_z = \frac{m_0 e \omega^2}{\sqrt{(k - m \omega^2)^2 + C^2 \omega^2}}$$

$$A_x = \frac{(C_\phi I - WL + C_\tau AL^2 - M_m \omega^2) P_x \pm C_\tau ALMi}{16 \pi^4 m M_m (f_{n1}^2 - f^2) (f_{n2}^2 - f^2)}$$

$$A_\phi = \frac{C_\tau ALP_x \pm (C_\tau A - m \omega^2) Mi}{16 \pi^4 m M_m (f_{n1}^2 - f^2) (f_{n2}^2 - f^2)}$$

B-2.2 The maximum displacement of the top edge of the foundation is equal to $A_x + h A_\phi$ where h is the height of the top surface of the foundation above the centre of gravity of the foundation and machine.

B-2.3 When centre of gravity of mass of machine and foundation, and the centroid of the foundation contact area with soil do not lie on the same vertical line, the vertical vibration is not independent of horizontal vibration and rocking. The equation governing the natural frequencies is

$$f_n^2 \epsilon^2 = \frac{i (f_{nz}^2 - f_n^2) (f_{n1}^2 - f_n^2) (f_{n2}^2 - f_n^2)}{(f_{nx}^2 - f_n^2) f_{nz}^2}$$

where ϵ = Eccentric distance from centroid of contact area of foundation with soil to the centre of gravity of mass of machine and foundation

$$i = \frac{M_m}{m}$$

B-2.4 Plot the expression on the right hand side versus f_n^2 assuming arbitrary values of f_n . Draw a straight line corresponding to the left hand side of the above equation. The abscissas of points of intersection of the two plots give the unknown roots f_{n1}^2 , f_{n2}^2 and f_{n3}^2 which are the three natural frequencies of the foundation. A typical plot is shown in Fig. 2.

NOTE — For foundations having a relatively small eccentricity, say 5 percent of the length of a side of the foundation contact area its effect may be neglected and computations may be based on formulac derived for $\epsilon = 0$.

B-3. Dynamic forces and moments should be calculated taking into consideration the fatigue factor and checked with the soil bearing pressure.

(Continued from page 2)

Foundations Subject to Dynamic Loads Subcommittee, BDC 43 : 1

Convener

SHRI T. K. D. MUNSI

Representing

Engineers In'ia Limited, New Delhi

Members

SHRI J. K. BAGCHI (*Alternate to*

Shri T. K. D. Munsi)

SHRI N. K. BASU
SHRI CHANDRA PRAKASH

Cemindia Company Limited, Bombay
Central Building Research Institute (CSIR),
Roorkee

DIRECTOR (TCD)

Central Electricity Authority, New Delhi

DY DIRECTOR (TCD) (*Alternate*)

DR M. K. GUPTA

University of Roorkee, Roorkee

SHRI A. P. MUKHERJEE

Metallurgical & Engineering Consultants (India)
Limited, Ranchi

SHRI A. RAMA RAO (*Alternate*)

SHRI A. K. MUKHERJEE

Development Consultants Limited, Calcutta

SHRI S. K. MANDAL (*Alternate*)

SHRI P. C. NAG

National Thermal Power Corporation Limited,
New Delhi

SHRI ASHOK TREHAN (*Alternate*)

SHRI M. V. PANDIT

Bharat Heavy Electricals Limited, Bhopal

SHRI E. C. H. C. REDDY (*Alternate*)

SHRI D. H. PATEL

The Fertilizer (Planning & Development) India
Limited, Dhanbad

SHRI S. P. GARAI (*Alternate*)

DR P. SRINIVASULU

Structural Engineering Research Centre (CSIR),
Madras

DR N. LAKSHMANAN (*Alternate*)

SHRI O. S. SRIVASTAVA

Cement Corporation of India, New Delhi

SHRI S. K. CHATTERJEE (*Alternate*)

DR V. V. S. RAO

Nagadi Consultants Private Limited, New Delhi

SHRI M. PRIYA KUMAR (*Alternate*)

BUREAU OF INDIAN STANDARDS

Headquarters;

Manak Bhavan, 9 Bahadur Shah Zafar Marg, NEW DELHI 110002

Telephones : 331 01 31, 331 13 75

**Telegrams : Manaksanatha
(Common to all offices)**

Regional Offices:

	<i>Telephones</i>
Central : Manak Bhavan, 9 Bahadur Shah Zafar Marg, NEW DELHI-110002	[331 01 31 331 13 75
*Eastern : 1/14 C.I.T. Scheme VII M, V. I. P. Road, Maniktola, CALCUTTA 700054	36 24 99
Northern : SCO 445-446, Sector 35-C, CHANDIGARH 160036	[2 18 43 3 16 41
Southern : C. I. T. Campus, MADRAS 600113	{41 24 42 41 25 19 41 29 16
†Western : Manakalaya, E9 MIDC, Marol, Andheri (East), BOMBAY 400093	6 32 92 95

Branch Offices:

'Pushpak' Nurmohamed Shaikh Marg, Khanpur, AHMEDABAD 380001	[2 63 48 2 63 49
‡Peenya Industrial Area, 1st Stage, Bangalore Tumkur Road BANGALORE 560058	[38 49 55 38 49 56
Gangotri Complex, 5th Floor, Bhadbhada Road, T. T. Nagar, BHOPAL 462003	6 67 16
Plot No. 82/83, Lewis Road, BHUBANESHWAR 751002	5 36 27
53/5, Ward No. 29, R. G. Barua Road, 5th Byelane, GUWAHATI 781003	3 31 77
5-8-56C L. N. Gupta Marg (Nampally Statlon Road), HYDERABAD 500001	23 10 83
R14 Yudhister Marg, C Scheme, JAIPUR 302005	[6 34 71 6 98 32
117/418 B Sarvodaya Nagar, KANPUR 208005	[21 68 76 21 82 92
Patliputra Industrial Estate, PATNA 800013	6 23 05
T.C. No. 14/1421, University P.O., Palayam TRIVANDRUM 695035	[6 21 04 6 21 17

Inspection Office (With Sale Point) :

Pushpanjali, 1st Floor, 205-A West High Court Road, Shankar Nagar Square, NAGPUR 440010	2 51 71
Institution of Engineers (India) Building, 1332 Shivaji Nagar, PUNE 411005	5 24 35

*Sales Office in Calcutta is at 5 Chowringhee Approach, P.O. Princep Street, Calcutta 700072 27 68 00

†Sales Office in Bombay is at Novelty Chambers, Grant Road, Bombay 400007 89 65 28

‡Sales Office in Bangalore is at Unity Building, Narasimharaja Square Bangalore 560002 22 36 71

AMENDMENT NO. 1 NOVEMBER 1985

TO

IS:2974(Part 1)-1982 CODE OF PRACTICE FOR DESIGN
AND CONSTRUCTION OF MACHINE FOUNDATIONS

PART 1 FOUNDATION FOR RECIPROCATING TYPE MACHINES

(Second Revision)

Corrigendum

(Page 21, clause B-2.4) - Delete the last sentence
'A typical..... Fig. 2'.

(BDC 43)

Printed at Simco Printing Press Delhi, India